

# The Low-Frequency Discone

MACK SEYBOLD, W2RYI\*

**If you've been looking for an antenna to feed with a flat line on all bands from 20 meters through 6 meters without switches or tricks, here's the answer.**

**S**UMMER IS A WONDERFUL TIME to crawl out of the basement into the sunlight to work on antennas. I was able to make that metamorphosis last summer, so if any of you pale-faced, hollow-eyed brass-pounders and microphone addicts plan to emerge from your winter haunts and enjoy the benefits of the great outdoors in the 1950 antenna season, I'd like to recommend a new and healthy antenna prescription.

The construction work on this new antenna will keep you out in the sun long enough to acquire a healthy tan, and the results of your efforts will be an amazing radiation system that performs the way amateurs have wanted antennas to perform since the days when Maxwell was a mathematician and not Jack Benny's automobile. As a matter of fact, Maxwell predicted what radio waves could do, but he didn't tell how they could do it. He certainly didn't dream up the discone—it took almost a century to get around to that development—but he undoubtedly would be pleased to know that at last there is available a method of coupling a radio signal to the ether in a clean-cut, efficient and fool-proof manner.

The discone is an antenna that has a low angle of radiation, presents a natural impedance match to a 52-ohm line over a 10:1 range of frequencies, and has a symmetrical configuration which minimizes the occurrence of standing waves on the outside of a coax feeder. The impedance-matching feature is probably the most remarkable thing about the discone. It certainly should please the amateur who has had difficulty obtaining low standing-wave ratios on transmission lines and antenna-coupler links. Actually, with a discone antenna, coax feeder, and low-pass filter, antenna couplers can be dismantled and forgotten.

## Amateur Wizards

Sometimes amateurs have to become magicians with stubs, shorting bars, gamma-matches, T-matches, delta-matches, field-strength indicators, s.w.r.-bridges, grid-dip meters, loading coils, hacksaws, and crowbars to get an antenna system to work well on one frequency. The discone doesn't require any of the cut-and-try magic to make it work perfectly on *any* frequency. From the time the first hole is drilled until the last nut is tightened, the only measuring equipment needed is a ruler, and all that remains to be done after that is to turn on the transmitter.

An article by Joe Boyer, W6UYH, started the amateurs on this discone deal. The July, 1949, *CQ* presented the electrical theory, and it described the construction of high-frequency discones. After reading Joe's article, I was interested in trying the idea at lower frequencies and determining if wire and aluminum angle pieces could be used instead of the sheet metal prescribed for the original discones.

\* c/o Tube Department, Radio Corporation of America, Harrison, N. J.

I also wanted to have an antenna for 10, 11, and 20 meters that would radiate and present a reasonably constant load to the transmission line in the television spectrum in order to study the effectiveness of low-pass filters for TVI. Some of the television interference tests also required a reduction of r.f. fields in the vicinity of the transmitter, so the symmetrical discone, promising a minimized standing-wave condition on the outside of the coax, looked like the answer to the antenna problem.

## Antenna Project

With encouragement from Joe Boyer by correspondence and with the approval of the XYL, I assumed responsibility for the top of the garage, and

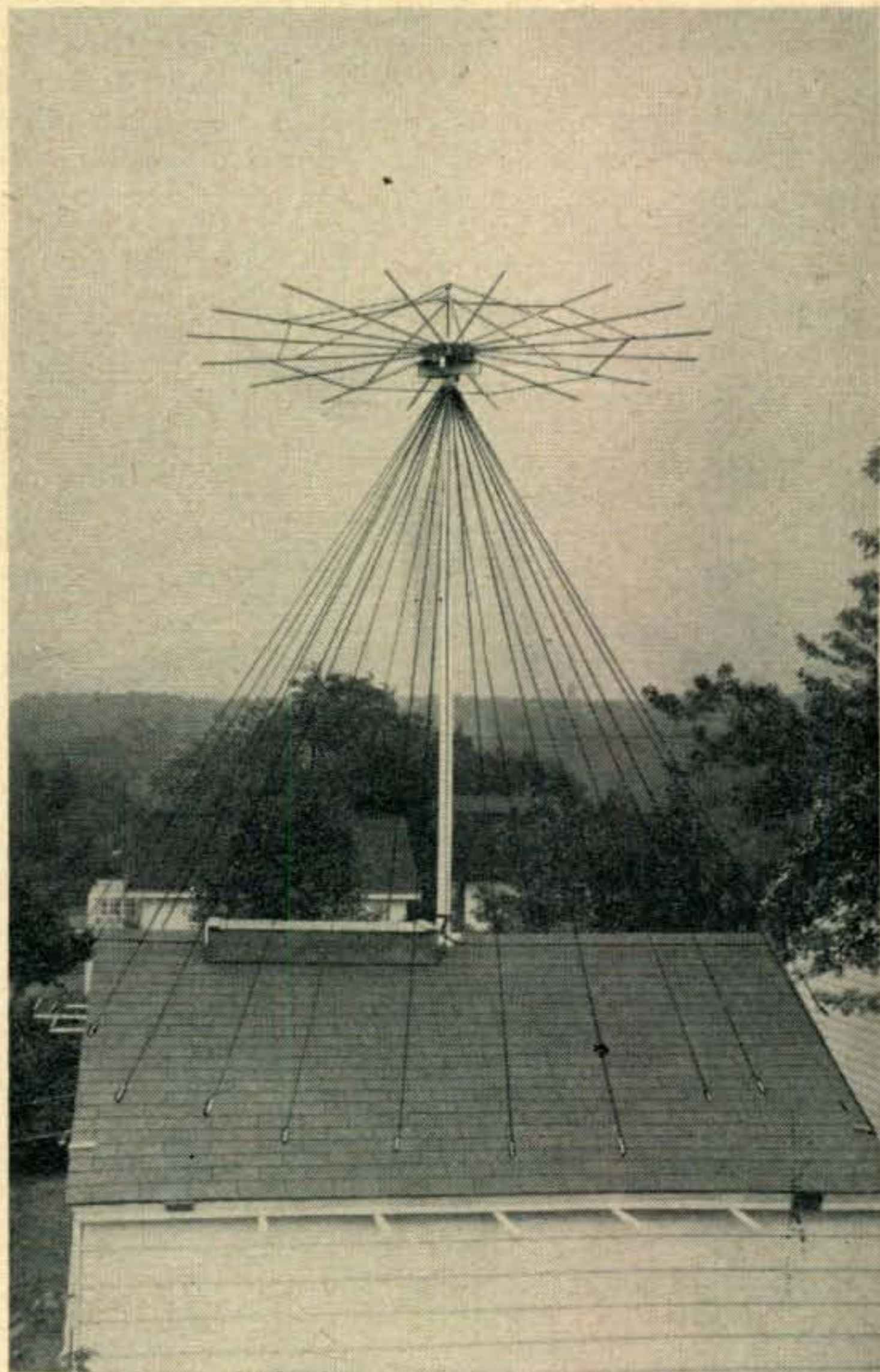

Fig. 1. Side view of the 11-mc discone. The disc is made of angle aluminum, and the cone consists of 28 wires which are fastened to specific points on the garage roof and to outriggers. The 52-ohm coax feeder runs up the mast and terminates at the tip of the cone and the center of the disc assembly.



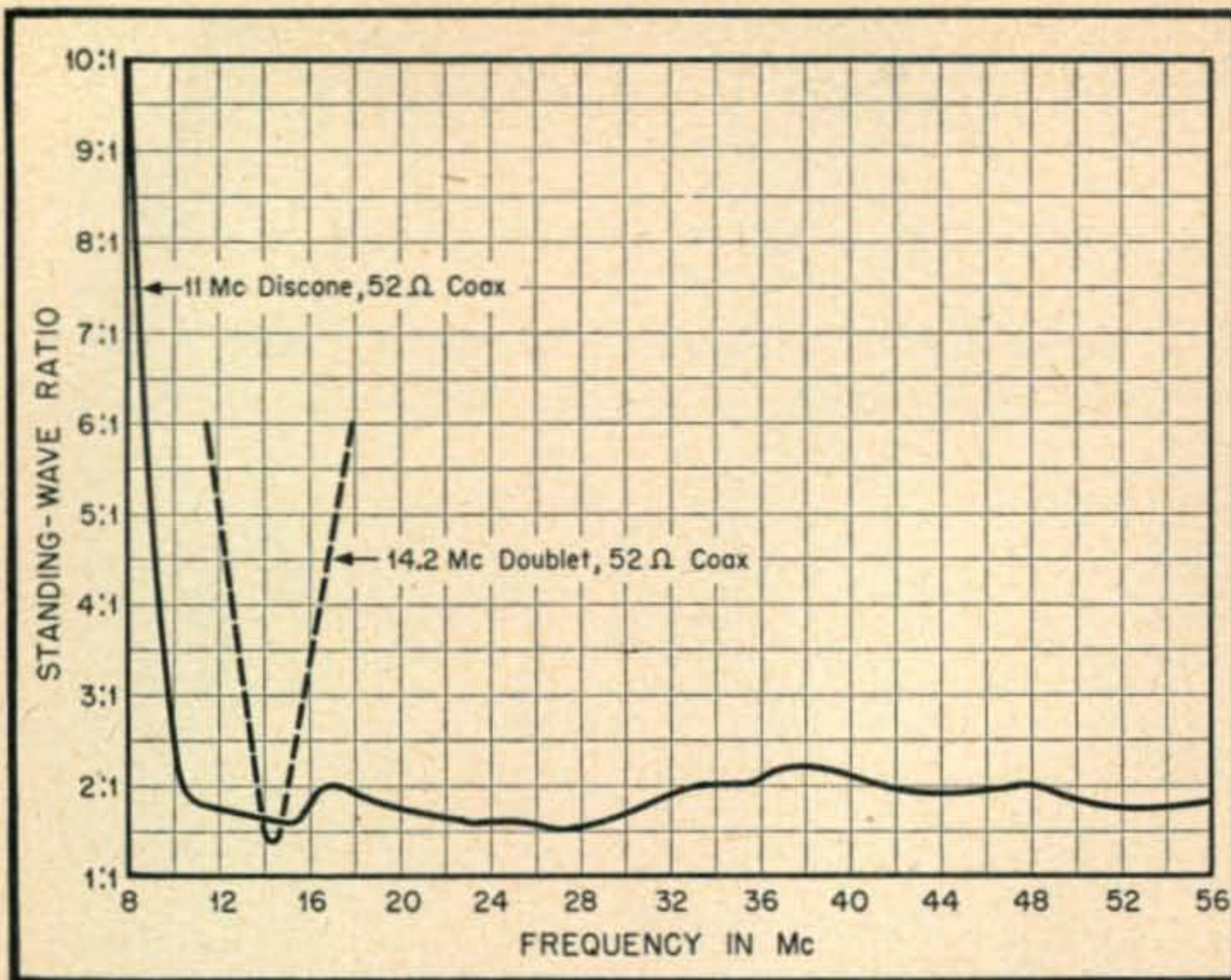

Fig. 2. A plot of standing wave ratio vs. frequency of the i.f. discone when fed with 52-ohm coax line. The broken line is the s.w.r. curve of a conventional 14-mc doublet.

began to work on the new antenna. There was just enough of the unknown and the element of uncertainty in the project "Monstro Discone" to make the adventure in the back yard during the summer of 1949 interesting and exciting. The results, however, were even more exciting, because when the antenna was finished it surprised everyone, including myself, by working perfectly, and it has been on the air ever since.

The specifications for the 11-mc discone are as follows:

- Length of cone wires .. 21'
- Disc diameter ..... 14' 6"
- Cone-to-disc spacing ... 1'
- Cone apex angle ..... 60°
- Diameter of cone base .. 21'
- Height of cone ..... 18'

This discone is the one shown in Fig. 1. It was cut for 11 mc because of an uncertainty in the safety factor required for good results at 14 mc. It is obvious from the s.w.r. curve, Fig. 2, that a much smaller safety factor is required.

For 20 meters, a 13.5-mc cut-off frequency should



Fig. 3. The 100-mc discone, as arranged for photographing by the jr. op, Susie. The aluminum disc is 20" in diameter, and the 60° cone is formed of 48 wires, each 37" long. This bird cage is permanently installed in the attic and is used mainly for 2-meter work.

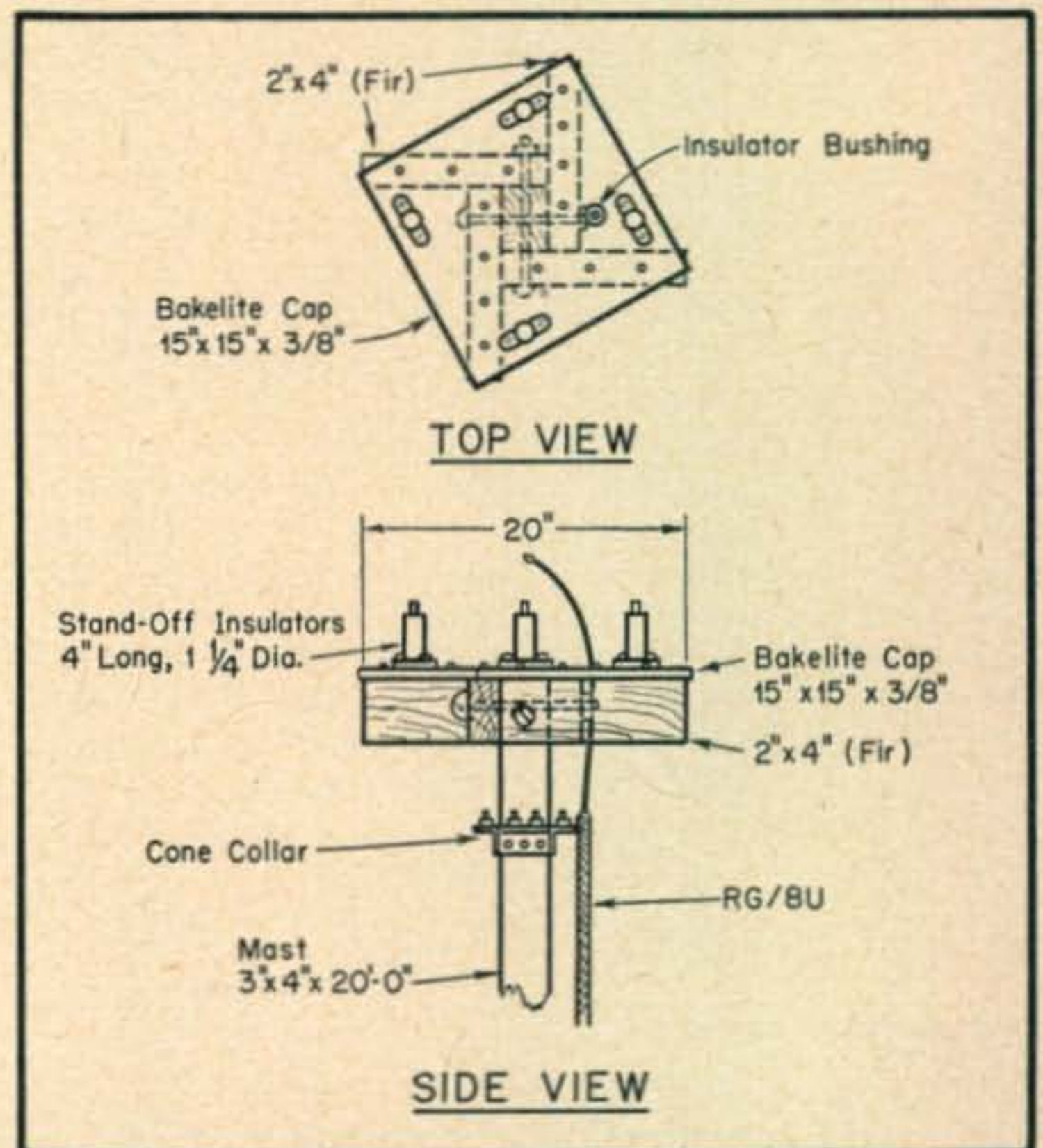

Fig. 4. The insulator assembly. The disc of the discone fits over the bolts in the tops of the standoff insulators. The angle-brass cone collar is fastened to the mast with wood screws.

be adequate, so the dimensions for a 20-meter discone, along with 15- and 11-meter antennas are given in the following table.

Table I

Cutoff frequency	13.5 mc	20.5 mc	26. mc
Length of cone wires	18'	12'	9' 6"
Disc diameter	12'	7' 10"	6' 2"
Cone-to-disc spacing	10"	6"	4"
Diameter of cone	18'	12'	9' 6"
Height of cone	15' 7"	10' 5"	8' 3"
Amateur bands	20, 15, 11, 10, 6, 2 meters	15, 11, 10, 6, 2 meters	11, 10, 6, 2, 1.5 meters



Joe Boyer's original article covers the discons for 50 mc and upwards, so the dimensions will not be given here. Fig. 3, shows a 100-mc model that now hangs from the rafters in the attic at W2RYI. Even though it is an "inside" antenna, it gets identical reports on comparison tests with an outside antenna cut for 2 meters. The "outside" radiator is a vertical, omni-directional antenna having three half-wave sections that are in phase. My 100-mc discone has 48 wires in the cone and an aluminum plate for the disc.

### 11-mc Discone

Open-mesh design simplifies construction of large discons and offers low wind resistance. One-third of the cone elements in the 11-mc discone are made of #14 Copperweld. The rest of the cone elements are solid copper wire, but they all act as guy wires in addition to their primary function of radiating r.f. power. Since there are 28 of these elements, the mast is held firmly and does not sway in the wind. In the January "hurricane," the wind blew down our television antenna, but the discone mast weathered the gale without a tremor.

The disc assembly is also constructed to offer minimum wind resistance. A sheet-metal disc 14.5 feet in diameter would require extensive reinforcement, strong anchorage, and would exert a tremendous force on the mast in a high wind. The disc must also be insulated from the mast and cone, so any dielectric used to support the disc would have to be capable of withstanding great stress and strain.

By using 16 radials instead of sheet metal for the disc, the electrical properties of a continuous surface are approached, but the wind resistance of the disc is minimized. Strong winds do produce torsion at the center of the disc, and the mast twists a few degrees, but with the base of the mast held firmly in place, the twist distributes itself throughout the length of the mast, and no immediate damage can be done. In time this action might produce longitudinal cracks in the wood, but in the nine months that the 11-mc discone has been in operation, no fissures have been found.

Because of the radial construction of the "disc" and consequent minimized wind resistance, stock stand-off insulations may be used to support the disc assembly. Four porcelain insulators 4" long and 1 1/2" in diameter, are bolted to a bakelite mast cap. The cap (Fig. 4) is fastened with wood screws to four short 2 X 4's which are nailed to the top of

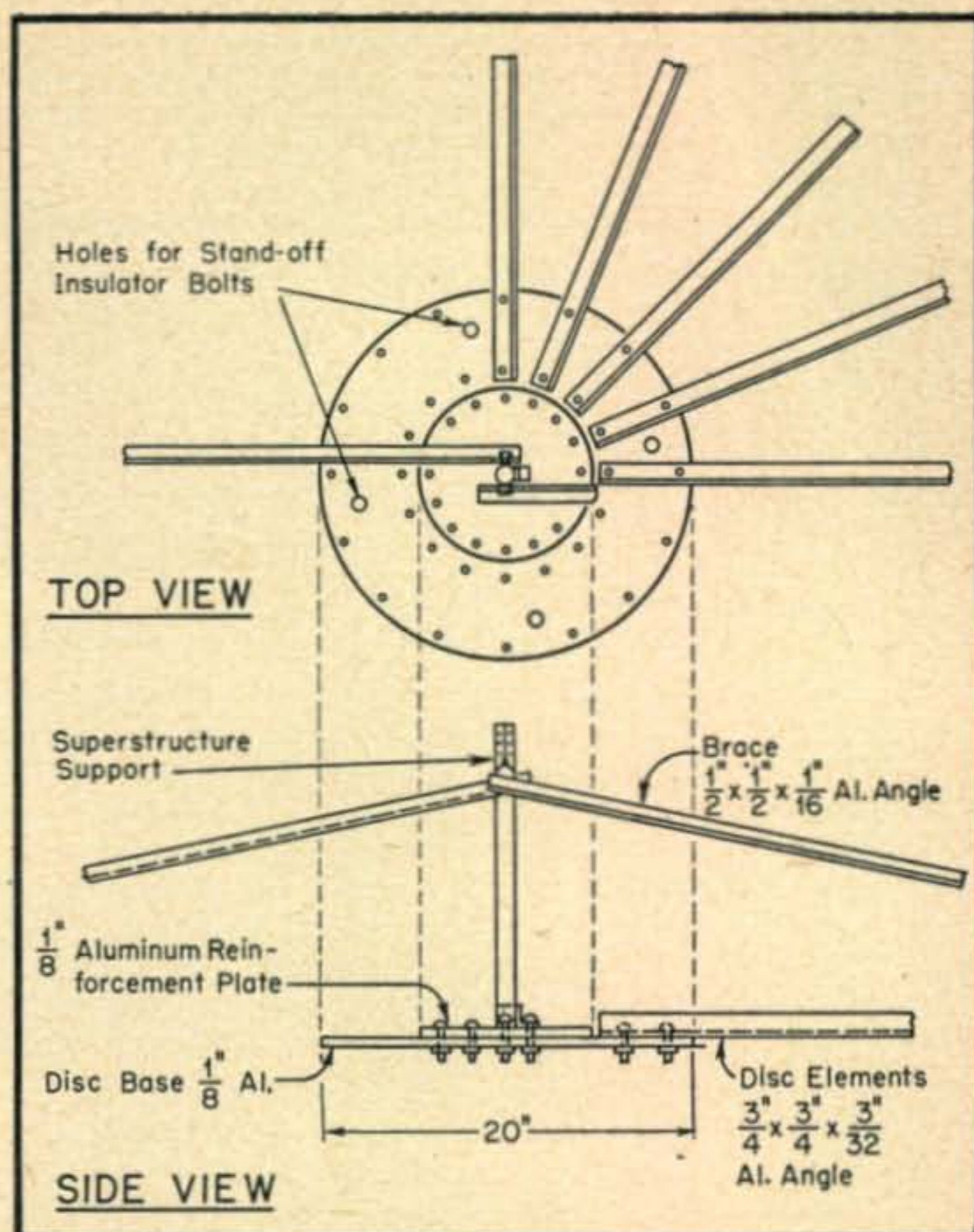

Fig. 5. Views of the center portion of the disc, partially assembled. Five of the 16 disc elements and two of the eight superstructure braces are shown.

the mast. This "insulating" structure makes a firm anchorage for the disc assembly which is bolted to the tops of the four porcelain insulators.

### Assembling the Disc

The disc structure can be assembled on the ground. An aluminum plate, 1/8" thick and about 20" in diameter, is drilled to take the radials, the insulator bolts, and the superstructure support. The superstructure support is a vertical member seated on top of the disc at the center, and it is held in place by two angle brackets which are bolted to a reinforcement plate (Fig. 5). After the aluminum-angle radials have been bolted loosely in place, the horizontal struts are added, then all bolts are tightened. Next, 8 aluminum-angle braces

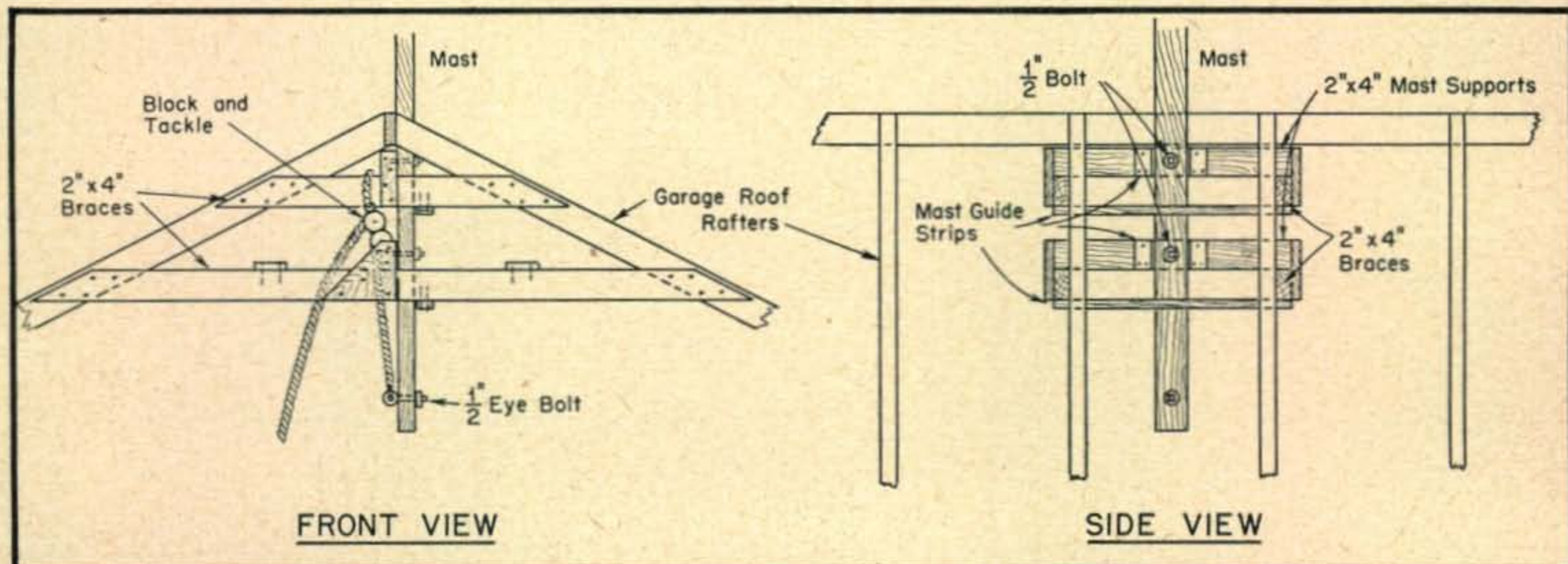

Fig. 6. Mast support inside the garage. The roof firring and shingles are not shown in order to simplify the drawing.







## THE NEW AMATEUR 144 MC TROUGH LINE FRONT END

2 stage RF amp.—mixer-oscillator—the hottest and most stable front end MODEL 1 (140-160 MC); MODEL 2 (80-120 MC).

These tuners have high gain, high image rejection, low noise factor. Can be used as converter or fed directly into IF amp.

10.7 MC IF amp.—80db gain—for FM or AM.

Special purpose receivers using trough line front ends, either tunable or fixed freq. crystal controlled up to 500 MC.

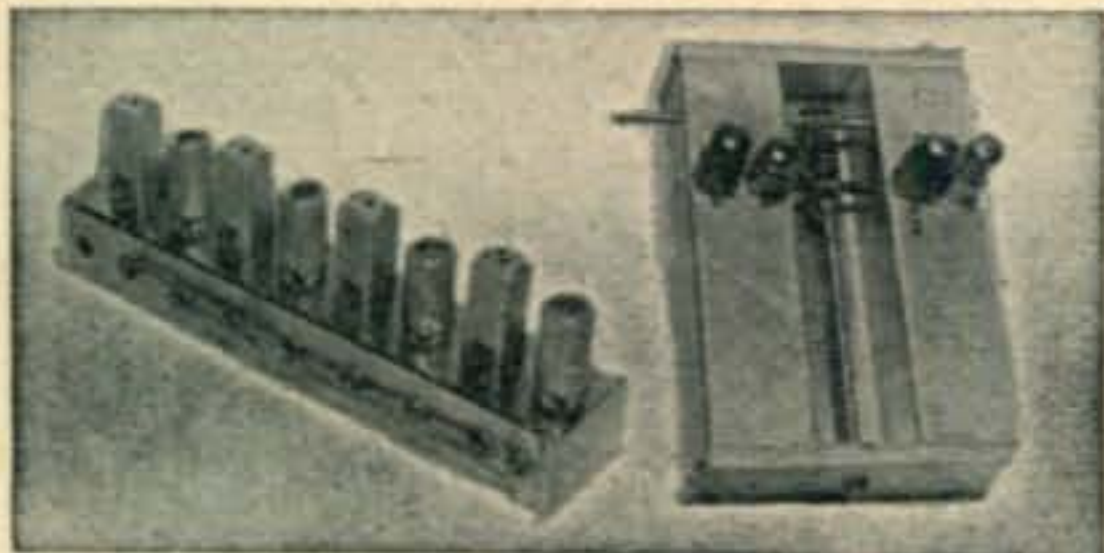

IF Amplifier \$50.00

Tuner \$18.95

**WARDELL SMITH, W2BRQ**

Manufacturing Communications Engineer

65 Glenwood Rd.

Upper Montclair, N. J.

### SPECIAL

BC610 CHOKES  
11 Henry .600 Amp.  
Herm. Sealed.  
\$7.95

**Atronic Corp.**  
Dept. C-7

1253 Loyola Ave.,  
Chicago 26, Ill.

### 10 METER BEAM ANTENNA \$15.95

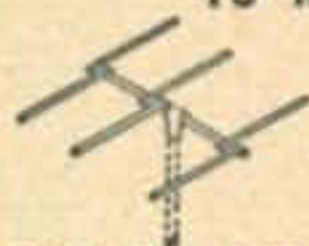

3 ELEMENTS  
SPECIAL

Volt-Ohm-Milliammeter 0-1 MA. 4"  
Fan Type. Diagram Incl. Makes 1000  
ohm per volt unit. Meter Only \$2.95  
METERS—3" PANEL TYPE  
0-10MA..\$2.00 0-1MA..\$2.50

### FLEXIBLE TUNING SHAFTS

For SCR274N & ARC5 receivers 6 foot length ea. 75¢

11 foot length \$1.25. 18 foot \$1.65.

For ARB, ARN7, BC433, MN26, GF11, BC229 receivers

10 foot \$1.95, 13 foot \$2.20, 15 foot \$2.45.

New, with all fittings. Guaranteed one year

Add 25¢ postage & handling.

**LONG ISLAND RADIO CO.**

164-21 Northern Blvd., Flushing, N. Y.

### AMATEURS

We offer for your early consideration a brand new power supply operating from a 115V 60 cycle line, which delivers 600V at 350 MA as well as 6.3V at 12 amperes. The internal design provides simultaneous outputs of 450V at 120 MA and 450V at 70 MA, as well as 600V at 250 MA. If you don't use the lower taps, you can draw a full 350 MA at 600V. When 866's are plugged in instead of the 1616's supplied, you may draw 700V out at 350 MA. These are constant duty ratings with a maximum ripple of less than 1%. Chassis and panel construction with the best possible parts. Net weight 62 lbs. Shipping weight 120 lbs. Our price, believe it or not, is only \$30, FOB.

The Overbrook Company, Overbrook 81, Mass.

### HQ FOR ALL H.F. MICROWAVE PARTS

WE OWN WHAT WE SELL AT SURPLUS PRICES

SA, SC, SD, SE, SF, SG, SL, SN, SO1, SO3, SO8, SO9, SO13, SQ, SU, TAJ, TBK, TBL, TBM, APE5, APR, APS2, APS3, APS4, APS6, APS10, APS15, ABA, QBF, QBG, QCQ, WEA, RAK, CPN3, CPN6, DAB, RC145, RC148. Write Us Your Needs and Let Us Quote

AVAILABLE IN STOCK ARC/5 EQUIPMENT Catalogue of  
**COMMUNICATIONS EQUIPMENT CO.** Other Surplus  
131 Liberty St., Dept. Q7. New York 7, N. Y.

## LOW-FREQUENCY DISCONE

(from Page 16)

easily if the mast has to be lowered at a time when the roof is icy and inaccessible.

The cone elements are fastened with just enough tension to keep them from sagging, and then, alternating from side to side and from back to the front of the garage, they are tightened to guy the mast uniformly. The coax is then connected to the transmitter, and the system is ready for operation.

### Feeder Systems

In order to keep the RG-8/U cable as far from the field of the discone as possible, I buried it at a depth of 10 inches for the 60 feet it traverses to the house. R.f. on the outside of the feeder is kept to a minimum, and no deterioration of the cable has been noticed thus far. A deeper ditch would have been dug if it had not been for the rocks. As far as transmissions are concerned, the coax can be strung eight feet above the ground with good results, but for the low-pass filter tests, the underground feeder operating into the discone presented an excellent, symmetrical load.

### Results

The 11-mc discone was finished on Labor Day last year. Since then, numerous comparison tests have been run on 20, 10, and 2 meters. Generalizations from the data obtained indicate that the vertically polarized signal emanating from the discone is about 2-db stronger than a signal from a vertical dipole. Polarization is important on 10-meter ground-wave contacts, but it is only important that the receiving antenna and transmitting antenna be polarized the same way. If they are not in the same plane, as much as 40-db difference in signal strength can be found. The discone is a sure-fire target for signals from the mobile gang, and many enjoyable QSOs have been had over long ground-wave paths.

Evidence for the behavior of the discone at 29 mc in the range from 1000 to 1500 miles is conflicting. At times a horizontal dipole was 6 to 9 db better. At other times the discone was superior. On the long skip paths, however, the discone was always superior to a horizontal or a vertical dipole.

On 20 meters, polarization did not have as marked an effect over ground-wave paths as it did on 10, and comparisons with a horizontal dipole over short-skip, long-skip and DX paths always showed the discone to be the better radiator. After a month or more of such tests, I was convinced that the 20-meter dipole was superfluous, and took it down.

Six-meter tests have not been run, but some are planned in the near future. At 2 meters the 11-mc discone does radiate, but it is 10 db below the level of the "bird-cage" 100-mc discone. Loading is no problem at 144 mc because the S.W.R. is still reasonable at that frequency, but the large spacing between the disc and cone is probably the cause of the poor radiation pattern. Naturally, I use the 100-mc discone for 2-meter work.

The 11-mc discone will be used at W2RYI on 21 mc as soon as the 15-meter band it made available. When that important date arrives, the big discone will be the basic antenna for operations on 20, 15, 11, and 10 meters, and I don't think it's going to be too long before an 829-B will be feeding that buried coax in the long-neglected 6-meter band.

When writing to our advertisers say you saw it in CQ